

# ACCU-CT<sup>®</sup> ACTL-1250 Series

## Split-Core Current Transformer Installation Guide



### Danger: Hazardous Voltages

Potential shock hazard from dangerous high voltage exists.

The ACTL-1250 series Accu-CT energy monitoring current transformers measure AC line current in circuits up to 600 Vac and nominal currents up to 600 Amps. They are split-core (opening) for ease of installation.

They may be field installed within distribution and control equipment such as panelboards, switchboards, industrial control equipment, and energy-monitoring/management equipment, to measure AC current on the service or branch circuit conductors.

The Accu-CT is used with electric energy meters, like the WattNode meters, or for other current monitoring purposes.

**Note: ACT-1250 models are identical to ACTL-1250 models.**

### Precautions

- **⚠ WARNING:** This product can expose you to chemicals including antimony trioxide, which is known to the State of California to cause cancer. For more information go to: [www.P65Warnings.ca.gov](http://www.P65Warnings.ca.gov).
- Only qualified personnel or **licensed electricians** should install the current transformer (CT). The line voltages of 120 Vac to 600 Vac can be lethal!
- Install in accordance with ANSI/NFPA 70, "National Electrical Code" (NEC). Follow all local electrical codes.
- Electrical codes prohibit installation of CTs in equipment where they exceed 75% of the wiring space of any cross-sectional area.
- Do not install CTs where they block ventilation openings.
- Do not install CTs in the area of breaker arc venting.

- The Accu-CT lead wires are considered Class 1 wiring (as defined by the NEC) and must be installed accordingly. They are not suitable for Class 2 wiring methods and should not be connected to Class 2 equipment.
- Verify that the line currents will not exceed the maximum current rating under normal operation (see **Specifications**).
- Do not install the CT where it may be exposed to temperatures below -30°C or above 75°C (-22°F to 167°F), excessive moisture, dust, salt spray, or other contamination.
- The Accu-CT can be damaged by sharp impacts or by being dropped. This can result in reduced accuracy.
- The current transformer cannot measure direct current (DC), and DC will degrade the AC accuracy.
- If the equipment is used in a manner not specified by the manufacturer, the protection provided by the equipment may be impaired.

### Pre-Installation Checklist

- The CT's rated current should normally be greater than or equal to the maximum current of the measured circuit. Ensure that the fuse or circuit breaker's rating does not exceed the CT's maximum continuous current rating.
- It is preferable to install the CT and meter or monitoring device close to each other. However, you may extend the CT wires by 300 feet (100 m) or more by using shielded twisted-pair cable and by running the CT wires away from high current and line voltage conductors.
- For highest accuracy, try to separate the CTs on different phases by 1 inch (25 mm) to minimize magnetic interference.

### Connecting the Current Transformer

- 1) **WARNING: To reduce the risk of electric shock, always open or disconnect the circuit from power-distribution system (or service) of building before installing or servicing current transformers.**
- 2) Point the SOURCE arrow toward the current source: the utility meter or the circuit breaker for branch circuits.  
**Note:** If the CT is mounted backwards, the measured power will be negative.
- 3) To open the CT, squeeze the knurled panels and pull / rotate the top open.
- 4) Make sure the mating surfaces are clean. Debris will increase the gap, decreasing accuracy.
- 5) Place the CT around the conductor and close the CT.
- 6) **Optional:** Secure the CT to the conductor with a cable tie.
- 7) **Optional:** For added security, wrap a cable tie around the outside of the CT or through the loops at the front of the CT.
- 8) Route the twisted black and white wires from the CT to the meter or monitoring device. **Be sure to route conductors so that they do not directly contact live terminals or busses.**
- 9) Connect the white and black wires to the terminals on the meter or monitoring device.

**Note:** If the white and black wires are reversed on a meter, the measured power will be negative.

**Note:** For the WattNode meter, align the white wire with the white dot on the label, and the black wire with the black dot.

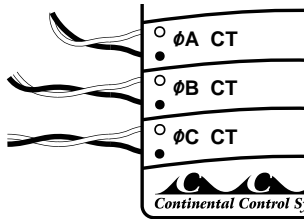

**Note:** Be careful to match the CT to the voltage phases being measured. Make sure the  $\phi A$  CT is measuring the current on the  $\phi A$  conductor, and the same for phases B and C. Use colored labels or tape to identify the wires.

## References

For more information see:

- <https://ctlsys.com/warranty-and-return-policy/> - Warranty
- <https://ctlsys.com/p/actl-1250/> - Product page
- <https://ctlsys.com/cat/current-transformer/> - Support

For more information about connecting current transformers to WattNode meters, see the appropriate WattNode meter manual.

## Specifications

See the ACTL-1250 datasheets for full specifications and details on options.

Model	Rated Primary Current	Maximum Continuous Current <sup>(1)</sup>
ACTL-1250-150	150 A	720 A
ACTL-1250-250	250 A	720 A
ACTL-1250-300	300 A	720 A
ACTL-1250-400	400 A	720 A
ACTL-1250-600	600 A	720 A
ACTL-1250-150 Opt 1V	150 A	400 A
ACTL-1250-250 Opt 1V	250 A	600 A
ACTL-1250-300 Opt 1V	300 A	600 A
ACTL-1250-400 Opt 1V	400 A	600 A
ACTL-1250-600 Opt 1V	600 A	720 A

**Other options:** C0.2, C0.3, C0.6, HF, 50Hz, 60Hz, FT, M

<sup>(1)</sup> The maximum continuous current is the highest current the CT can sustain without overheating.

## Ratings

### Overvoltage and Measurement Category:

600 Vac, CAT IV (service entrance) for pollution degree 2  
250 Vac, CAT III for pollution degree 3

**Line Frequency:** 50 to 60 Hz

**Secondary (Output) Voltage at Rated Amps:** 0.33333 Vac

**Optional:** 1.000 Vac (add "Opt 1V" to the model number)

**Optional:** 100 mA or 1 A output. Contact sales for details.

## Environmental

**Operating Temperature:**  $-30^{\circ}\text{C}$  to  $+75^{\circ}\text{C}$  ( $-22^{\circ}\text{F}$  to  $167^{\circ}\text{F}$ )

**Altitude:** up to 3000 m (9840 feet)

**Operating Humidity:** 5 to 95% relative humidity (RH)

## Pollution Degree:

- 2 (controlled environment) for CAT IV, 600 Vac
- 3 (harsh environment) for CAT III, 250 Vac

**Indoor Use:** Suitable for indoor use.

**Outdoor Use:** Suitable for outdoor use when mounted in a NEMA 3R or 4 (IP 66) rated enclosure, provided the ambient temperature will not exceed  $75^{\circ}\text{C}$  ( $167^{\circ}\text{F}$ ).

## Electrical

### Accuracy:

For detailed accuracy specifications, see the datasheet or <https://ctlsys.com/product/accu-ct-act-1250-split-core-ct/>

**Type:** Voltage output, integral burden resistor

**Protection:** output clamped at 6 Vac by zener diode

**Lead Wire:** 2.4 m (8 feet), 20 AWG (18 AWG prior to March 2021)

**Optional:** up to 30 m (100 feet)

**UL Listing:** UL 2808, X0BA, UL file number E363660

**cUL Listing:** CAN/CSA C22.1 No. 61010-1, X0BA7, E363660

## Mechanical

**Outside Dimensions:** 4.50 in x 3.30 in x 1.58 in (114 mm x 83.4 mm x 40.2 mm)

**Conductor Opening:** modified ellipse 1.77 in x 1.26 in (45.0 mm x 32 mm)

**Weight:** 13.9 oz (395 gm)

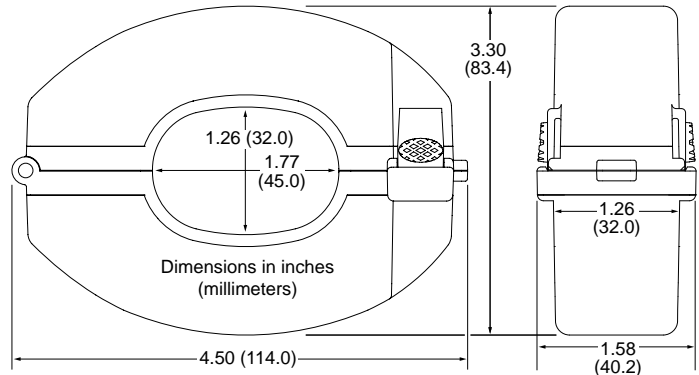

Continental Control Systems, LLC  
2150 Miller Dr. Suite A, Longmont, CO 80501, USA  
<https://ctlsys.com>  
+1-303-444-7422

Document number: ACTL-1250-Install-Guide-1.11  
Revision Date: January 10, 2022

©2014-2022 Continental Control Systems, LLC  
Accu-CT® and WattNode® are registered trademarks of Continental Control Systems, LLC.  
WattNode® is a registered trademark of Continental Control Systems, LLC.